

AIR CONTROL ACCESSORY KIT

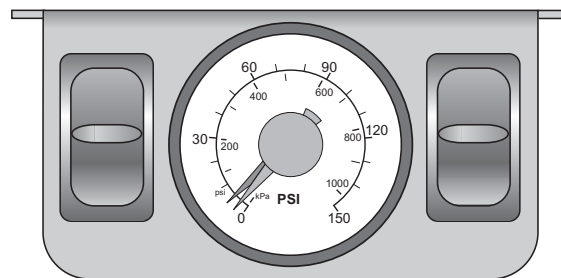

INSTALLATION INSTRUCTIONS

Congratulations on your purchase of a new Air Control Accessory Kit. This kit was designed to provide inflation control of your air helper springs. This kit will be an asset to your vehicle, meeting your air supply needs.

Please take a few minutes to read through the instructions, identify the components, and learn how to properly install your Air Control Accessory Kit.

NOTE:

The Air Control Accessory Kit can be used with most air helper spring products. If you are installing an air helper spring kit, do not install the air line tubing into the air springs as stated in the air helper spring manual. If you are adding the Air Control Accessory Kit to an existing air helper spring system, you will need to deflate the air springs and remove the air line tubing.

NOTE ON CONNECTING THE AIR LINE TUBING

Cut the air line tubing as square as possible. To connect the air line tubing to the fittings, push the tubing into the fitting as far as possible. If for any reason the tubing must be removed, make sure the air helper springs are deflated, then push the collar of the fitting toward the body of the fitting and the tubing can be removed. To reassemble, make sure the tubing is cut square and push back into the fitting.

PARTS LIST

COMPRESSOR	9285	1	COMPRESSOR T-FITTING	1
AIR TANK	9124	1	PUSH-TO-CONNECT T-FITTING	3
PRESSURE SWITCH	9016	1	PUSH-TO-CONNECT MALE FITTING	2
DUAL AIR CONTROL PANEL		1	PUSH-TO-CONNECT INFLATION VALVE	1
30 FT. AIR LINE TUBING	9008	2	NYLON TIE	12
25 FT. EXTENSION HOSE		1	15 FT. 18 GAUGE WIRE	1
#10-32 x 1" MACHINE SCREW		6	15 FT. 16 GAUGE WIRE	1
#10-32 LOCK NUT		6	FEMALE TERMINAL	4
#10 FLAT WASHER		10	RING TERMINAL	2
3/8" -16 1" HEX BOLT		2	WIRE CONNECTOR	2
3/8" -16 FLNAGED HEX NUT		2	IN-LINE FUSE HOLDER	1
3/8" FLAT WASHER		2	20 AMP BLADE FUSE	1
5/16" FLAT WASHER		2		

STEP 1 - PREPARE THE COMPONENTS

A) COMPRESSOR

Install the threaded end of the T-fitting into the compressor head. Tighten the fitting sufficiently to engage the orange thread sealant. Next, install the pressure switch into the female end of the T-fitting. Install the female terminal connector from the compressor onto *either* spade on the pressure switch *see Figure "A"*.

B) AIR TANK

Thread two (2) 1/4" NPT male push-to-connect fittings into the air ports on the air tank *see Figure "A"*. Tighten the fittings securely to engage the orange thread sealant.

C) GAUGE PANEL

Cut two pieces of air line tubing 3-1/2" in length, making the cut as square as possible. Insert one end of each 3-1/2" piece of air line into the hole marked *IN* on the back of the paddle switches *see Figure "C"*. Insert the remaining ends of the 3-1/2" lengths of tubing into a push-to-connect T-fitting *see Figure "A"*.

STEP 2 - SELECT A MOUNTING LOCATION

A) COMPRESSOR ATTACHMENT

Begin by removing the negative battery cable. Select a convenient location to mount the compressor. This location should provide ample air flow and be protected from airborne debris and moisture. The mounting surface should be rigid to support the compressor, such as under the hood on a fender well or in a vented storage compartment. (*Note: The compressor can be mounted in any orientation.*)

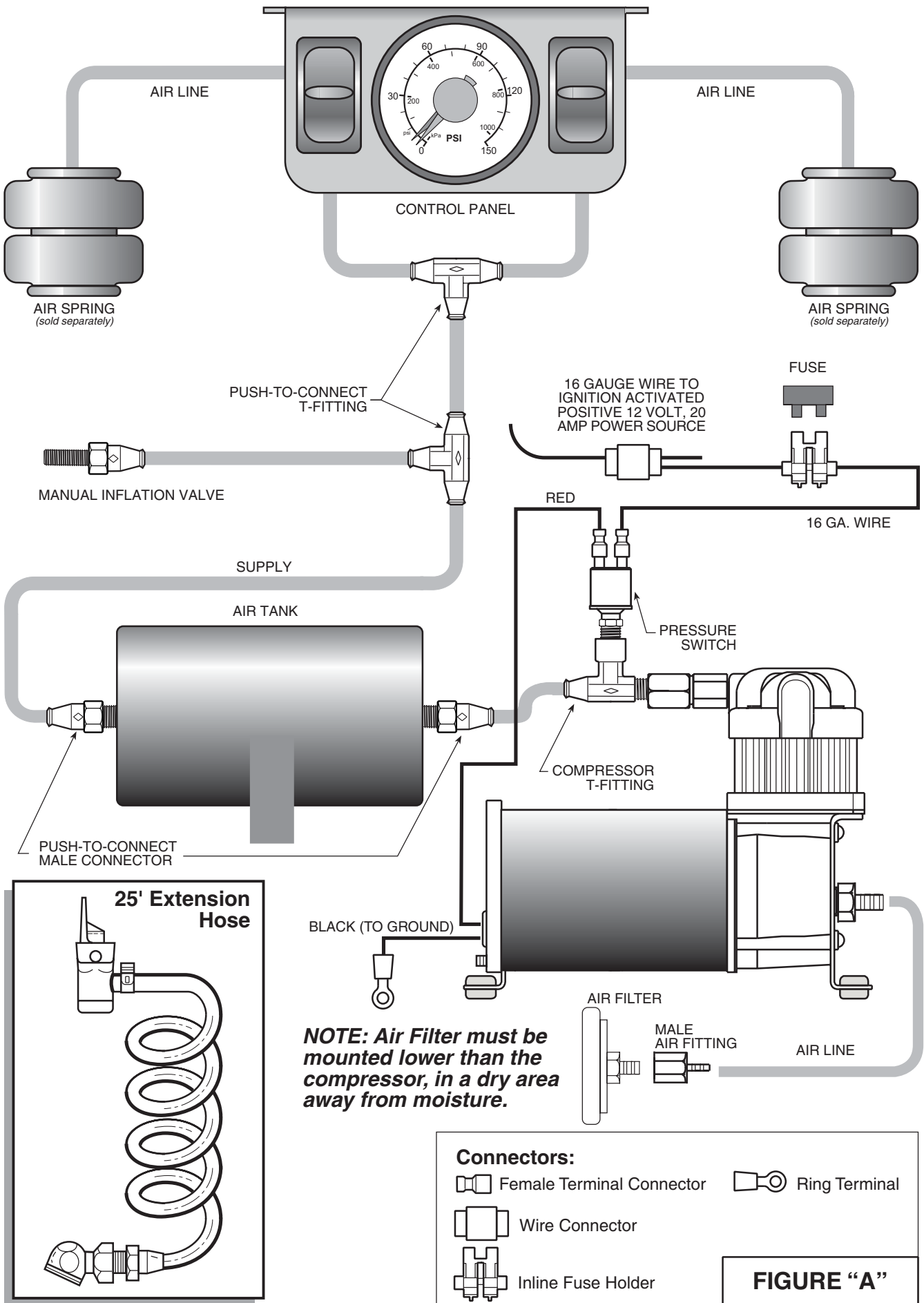

FIGURE "A"

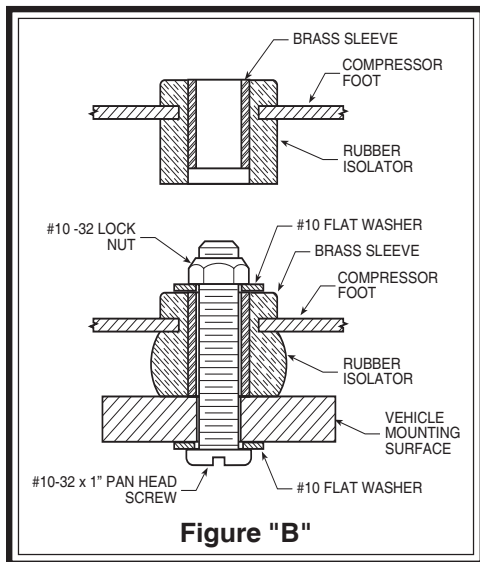

Figure "B"

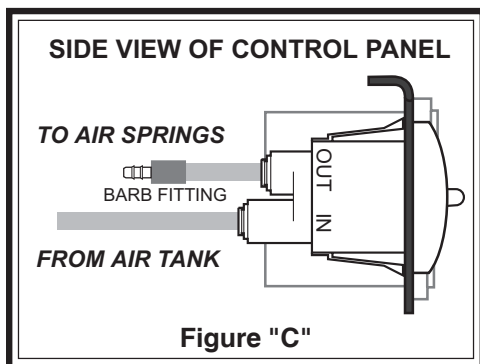

Figure "C"

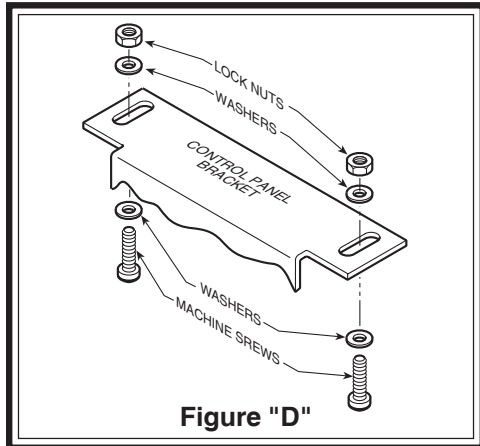

Figure "D"

Using the compressor as a template, mark and drill four 3/16" holes. Any burrs in the holes should be removed to prevent damage to the rubber isolators. Mount the compressor using the #10-32 x 1" machine screws, #10-32 lock nuts, and #10 washers supplied with the kit *see Figure "B"*. Maximum vibration isolation can be achieved by properly mounting the compressor. The machine screw and nut should be tightened only enough to bottom-out the brass insert *see Figure "B"*. **DO NOT OVER-TIGHTEN.** Over-tightening will crush the brass insert and the insulator, thereby reducing vibration isolation.

B) AIR TANK ATTACHMENT

Select a location to mount the air tank. This should be in a protected location to prevent damage from rocks or airborne debris. Mark and drill two 7/16" holes 2-1/2" apart. Bolt the air tank in place using the 3/8" -16 x 1-1/2" hex bolts with the 3/8" -16 flanged lock nuts and 3/8" washers provided. Ensure that the installation allows unrestricted access to the air ports on the tank.

C) GAUGE PANEL ATTACHMENT

Select a mounting surface for the gauge panel under the dashboard of your vehicle or other protected location. Using the gauge panel as a template, center mark the mounting holes on the dashboard. Drill a 3/16" hole on each center mark *see Figure "D"*. **Do not attach the panel to the dashboard at this time.**

STEP 3 - ROUTE THE AIR LINE

A) AIR TANK AND COMPRESSOR TO GAUGE PANEL

Cut a piece of air line tubing that will reach from the gauge panel mounting location to the air tank. Insert the end of the air line tubing into the T-fitting on the back of the gauge panel. Route the air line from the gauge panel to the air tank *see Figures "A" & "C"*. It may be necessary to drill a hole in the fire wall to route the air line. Make sure that the air line tubing is protected from sharp edges. Insert the other end of the tubing into either push-to-connect fitting on the air tank. Secure the tubing to the vehicle with the provided nylon ties. **Do not fold or kink the air line tubing.**

Cut a piece of air line tubing that will reach from the air tank to the compressor. Insert one end of the air line tubing into the brass T-fitting on the compressor. Route the tubing to the air tank, avoiding sharp edges and direct heat. Insert the other end of the air line tubing into the remaining push-to-connect fitting on the air tank *see Figure "A"*. Secure the tubing to the vehicle with the provided nylon ties.

B) GAUGE PANEL TO AIR SPRINGS

Cut two lengths of air line tubing that will reach from the gauge panel to each of the air helper springs. It may be necessary to drill a hole in the fire wall to allow the air line tubing to reach the rear of the vehicle. Ensure that the air line tubing is protected from sharp edges. Before installing the tubing to the gauge panel,

soak one end of the tubing in hot water for a few minutes to soften the tubing. Slide the tubing onto the barbed fitting on the back of the gauge panel as far as possible. Do not use pliers to work the air line onto the barbed fitting, as the tubing may be damaged.

Install the other end of the air line tubing into the push-to-connect fitting on the air spring *see Figure "A"*. Insert the tubing as far as possible into the fitting. Route the tubing to avoid sharp edges and direct heat from the exhaust system. Secure the tubing to the vehicle with the nylon ties provided.

STEP 4 - INSTALL THE MANUAL INFLATION VALVE

Cut the air line tubing in a convenient location between the gauge panel and the air tank. Install a push-to-connect T-fitting between the gauge panel and the air tank *see Figure "A"*. Select a location on the vehicle for the manual inflation valve. This location can be anywhere on the chassis of the vehicle, as long as it is in a protected location so the valve will not be damaged, but maintain accessibility for the air chuck. Drill a 5/16" hole and install the air inflation valve using two 5/16" flat washers per valve *see Figure "F"*. Route the air line tubing from the T-fitting to the inflation valve. Avoid direct heat from the exhaust pipe and away from sharp edges. Secure the tubing with the provided nylon ties. Push the end of the air line tubing into the inflation valve as far as possible *see Figure "F"*.

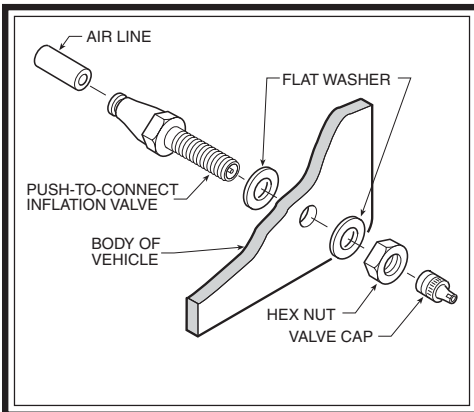

STEP 5 - ROUTE THE ELECTRICAL WIRE

All necessary electrical wire and connectors have been included with this kit. Review the electrical schematic before beginning installation see Figure "A".

Crimp a blue ring terminal onto the end of the black lead from the compressor. Secure the ring terminal to a grounded component of the chassis.

Next, route a length of wire from the pressure switch to a positive 12 volt, 20 amp, ignition activated power source on the vehicle. Cut a length of 16 gauge wire from the 6' length included with this kit. Crimp a blue female terminal connector onto the black lead from the compressor. Install the female terminal connector over the remaining spade on the pressure switch. Connect the lead from the pressure switch to the 12 volt wire with a wire connector. Slide the wire connector over the existing wire and insert the un-stripped lead from the pressure switch into the wire connector. Close the wire connector over both wires with pliers see Figure "G".

Next, install the in-line fuse holder in the positive pressure switch lead. Cut the pressure switch lead near the wire connector and insert the un-stripped ends of the wire into the fuse holder. Close the fuse holder over the wires with pliers and install the fuse see Figure "H".

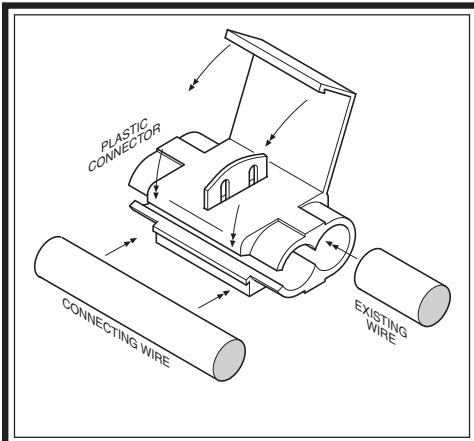

STEP 6 - WIRE THE GAUGE PANEL FOR ILLUMINATION

From the 15' length of 18 gauge wire, cut a length that will reach from the gauge panel to a dashboard illumination wire. This will allow the gauge panel light to be activated with the dashboard lights. Strip one end of the wire 1/4" and crimp a red female terminal connector onto the wire. Slip the female connector onto either spade on the back of the gauge see Figure "I". Attach the other end of the wire to a dashboard illumination wire using a wire connector. Slip the wire connector over the existing dashboard wire and insert the un-stripped gauge panel wire into the wire connector. Close the wire connector over the wires with pliers see Figure "G". Route a length of 18 gauge wire from the gauge panel to a suitable ground source. Strip both ends of the ground wire and crimp a red female terminal connector on one end and a red ring terminal on the other end. Slip the female terminal connector over the remaining spade on the back of the gauge and secure the ring terminal to the ground source see Figure "I".

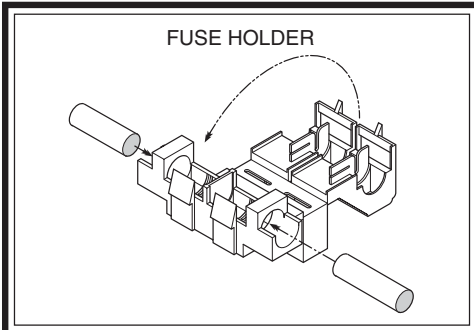

STEP 7 - ATTACH THE GAUGE PANEL TO THE DASHBOARD

Install the gauge panel on the dashboard where the holes were drilled in Step 2C. Attach the gauge panel to the dashboard or other mounting surface using the enclosed #10-32 x 1" machine screws, #10-32 lock nuts, and #10 washers see Figure "D".

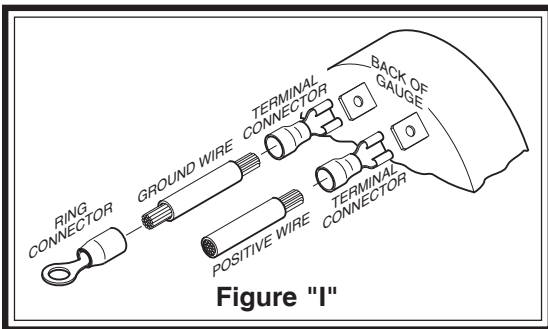

Figure "I"

STEP 8 - TEST THE SYSTEM

With the Air Control Accessory Kit and air helper springs installed, you are ready to test the system. Re-attach the negative battery cable. Turn on the ignition. The compressor will start and build pressure in the system. Push the paddle switch upward to inflate the air springs. The gauge will display how much air pressure is in the air springs. Inflate the air helper springs to 70 P.S.I. and check the fittings for air leaks with an applied solution of soap and water. If a leak is detected at a tubing connection, check to make sure that the tube is cut as square as possible and that it is pushed completely into the fitting. The tubing can easily be removed from the fitting by first releasing the pressure from the air spring, then by pushing the collar towards the body of the fitting and then pulling out the air line tubing.

SYSTEM OPERATION

The air control accessory kit allows the air springs to be inflated from the inside of the vehicle. Push the paddle switch up to inflate the air springs and down to deflate the air springs.

If the air compressor fails to operate for any reason, air can be introduced into the system by using the manual inflation valve installed with the air accessory kit. This can be accomplished by inflating the system through the manual inflation valve.